

ASSET Steel Posts in several types of section have been in satisfactory service for many years.

For car park installations or loading areas where vehicle contacts are likely to be more frequent but less severe, a more rigid support is required to counter the tendency for posts to push out of line. In such cases mounting in concrete should be considered.



RIGID STEEL POSTS

Typical arrangement at RSJ Post in Concrete Surround.

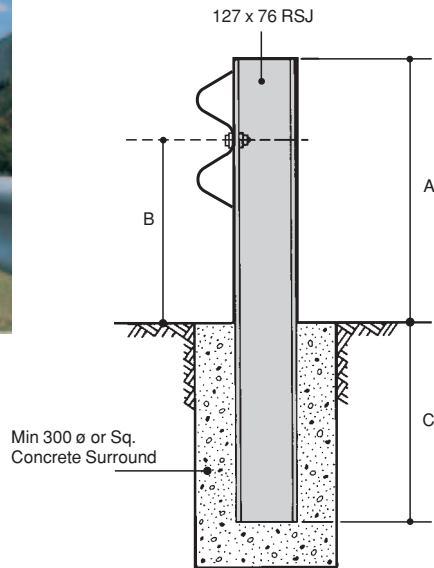

P 224 Type 3/1.1			P 224 Type 3/1.5		
A	B	C	A	B	C
600	412	500	800	612	700

'Z' Section Posts

125 x 90 x 6mm 'Z' Post, available in 1225mm lengths. Suitable for general contracts and for use with off-set bracket.

125 x 90 x 5mm 'Z' Post, available in 1220mm lengths.

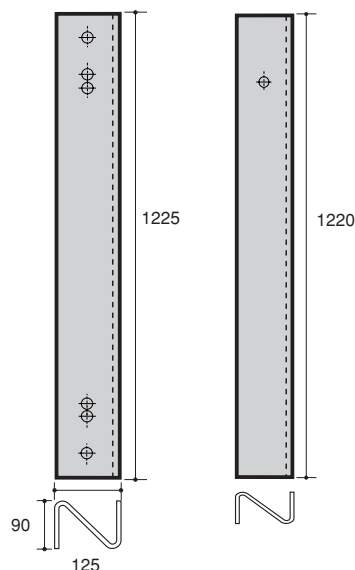

BOLT DOWN RIGID STEEL POSTS



Where barriers are to be mounted on bridge decks, floor slabs, foundation blocks etc., specially fabricated steel posts with base plates are employed.

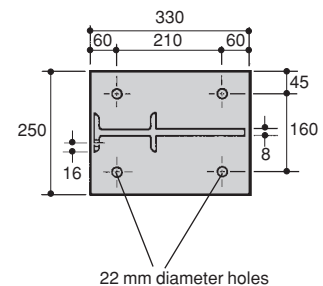
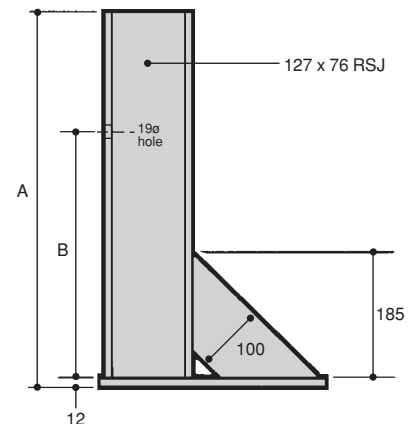

P 224 Type 1*		P 224 Type 2	
A	B	A	B
560	370	760	570

*Car park height